



Atop Technologies, Inc.

## IP68 Rated 2-Port Serial Server

SE8502-M12 Series

## Hardware Installation Guide

Version 1.0

Updated on October, 2012



Tel: 886-3-5508137  
Fax: 886-3-5508131  
www.atop.com.tw

P/N: 89900435G

## Introduction

Thank you for choosing the Atop IP68 Rated 2-Port Serial to Ethernet Serial Device Server. The SE8502-M12 Series provide industrial grade media conversion between Ethernet and RS-232/RS-422/RS-485. This Guide covers four product models:

- SE8502-M12  
IP68 Rated 2-Port RS-232/422/485 to Ethernet Serial Device Server
- SE8502-M12 (DIN-Rail)  
IP68 Rated 2-Port RS-232/422/485 to Ethernet Serial Device Server with DIN-Rail Mounting Kit
- SE8502-Sis-M12  
IP68 Rated 2-Port RS-422/485 to Ethernet Serial Device Server, 2KV Isolation on serial ports
- SE8502-Sis-M12 (DIN-Rail)  
IP68 Rated 2-Port RS-422/485 to Ethernet Serial Device Server with DIN-Rail Mounting Kit, 2KV Isolation on serial ports

## Package Check List

Inside the package you will find the following items:

- SE8502-M12 / SE8502-M12 (DIN-Rail) / SE8502-Sis-M12  
SE8502-Sis-M12 (DIN-Rail) x 1
- DIN-Rail Kit (only for SE8502-M12 (DIN-Rail) and SE8502-Sis-M12 (DIN-Rail)) x 1
- Hardware Installation Guide (Warranty card is included) x 1
- Product CD (information on the product as well as software) x 1

Note: please contact your sales representative if any of the above mentioned products are missing upon purchase.

## LED Indicators

Name	LED	Status	Description
LAN	Orange	On	Ethernet is connected at 10Mbps
		Off	Ethernet is disconnected
	Green	On	Ethernet is connected at 100 Mbps
		Blinking	Data is transmitting on Ethernet
COM	Orange	On	Data is transmitting on COM port (Tx)
		Off	Data is not transmitting on COM port (Tx)
	Green	On	Data is transmitting on COM port (Rx)
		Off	Data is not transmitting on COM port (Rx)
RUN	Red	On	Device is powered on
		Off	Device is not powered on
	Green	On	Firmware is not running
		Blinking	Firmware is running normally

## Hardware Installation

1. Unpack the Serial Server; make sure it has not suffered any visible external damages.
2. Proceed to do grounding on the device. This step is of extreme importance since the back of the product has its ground metal side exposed. For grounding just connect the corresponding grounding cable to the grounding point, make sure the cable's end has a solid contact with the grounding metal side.



### ATTENTION:

Please make sure that the device is grounded properly before proceeding.

3. Connect the device to a suitable power source.
4. Connect the device to the Ethernet network or a PC.
5. Always make sure that your PC is on the same network's subnet as your SE8502-M12.
6. Connect SE8502-M12's serial port to a serial device.
7. Proceed then to mount your SE8502-M12 either to a wall or to your DIN rail (depending on your current environment and choice of model).

## Software Setup

Default Network Setting	
User Name	admin
Password	null (leave it blank)
LAN	
IP	10.0.50.100
Mask	255.255.0.0
Gateway	10.0.0.254

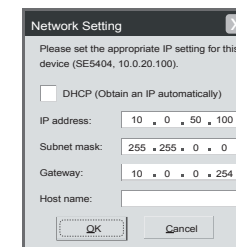

### DHCP (Dynamic IP):

A DHCP server can automatically assign an IP address and other related network settings when SE8502-M12 acts as a DHCP Client; by default, the DHCP client function on SE8502-M12 is disabled; you may activate the DHCP client function by executing our Serial Manager® Utility.

### Assign a Static IP address by:

- Configure by Telnet
  - Make sure the PC is on the same network as SE8502-M12.
  - Telnet to SE8502-M12 using DOS command "Telnet IP\_address 23". Example: telnet 10.0.50.100 23.
  - SE8502-M12's network, link mode and COM port settings can be configured in the telnet window.
- Configure by Serial Manager® Utility  
Use Serial Manager® Utility on Product CD to configure the SE8502-M12. First click on "Config" then assign a static IP.
- Configure by Web Browser
  - Make sure the PC is on the same network as SE8502-M12.
  - Open a web browser; enter the IP address of SE8502-M12 in the address bar. The default user name is admin and default password is null (leave it blank).
  - SE8502-M12's network, link mode and COM port settings can be configured on different web pages.
  - Click on "Save Configuration" to save settings.
  - Click on "Restart" button to initiate the change if necessary.

# Product Description

## Interfaces

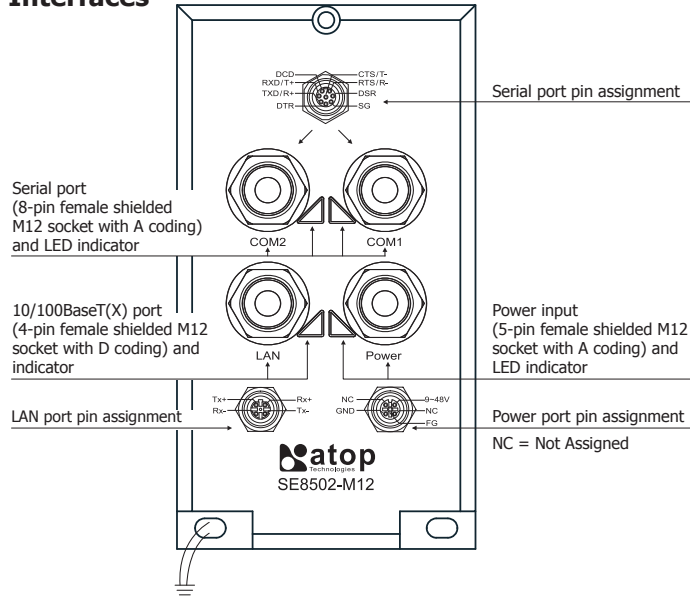

### Note:

Proper grounding will minimize the effects of noise due to electromagnetic interference (EMI). Please install the ground connection from the ground screw to the grounding surface before connecting the device.

# Warranty Policy

## Warranty Conditions

Products supplied by Atop Technologies are covered in this warranty for sub-standard performance or defective workmanship.

The warranty is not, however, extended to goods damaged in the following circumstances:

- (a) Excessive forces or impacts
- (b) War or an Act of God: wind storm, fire, flood, electric shock, earthquake
- (c) Use of unqualified power supply, connectors, or unauthorized parts/kits
- (d) Replacement with unauthorized parts

## RMA and Shipping Costs Reimbursement

Customers shall always obtain an authorized "RMA" number from Atop before shipping the goods to be repaired to Atop. When in normal use, a sold product shall be replaced with a new one within 3 months after purchase. The shipping cost from the customer to Atop will be reimbursed by Atop.

After 3 months and still within the warranty period, it is up to Atop whether to replace the unit with a new one; normally, as long as a product is under warranty, all parts and labor are free of charge to the customers.

After the warranty period, the customer shall cover the cost for parts and labor. Three months after purchase, the shipping cost from the customer to Atop will not be reimbursed, but the shipping cost from Atop to the customer will be paid by Atop.

## Limited Liability

Atop shall not be held responsible for any consequential losses from using Atop's product.

## Warranty Period

Product Categories	Warranty
Ethernet Switches	5 Years
Wireless	
Serial Device Servers	
Modbus Gateways	
Embedded Device Servers	3 Years
DIN-Rail Power Supplies	
Power Adaptors	
Antennas	1 Year
Other Accessories	

The warranty certification will not be effective until an authorized stamp issued by Atop's overseas agents.

Purchase Date:        /        /        (yyyy/mm/dd)

Serial Number:

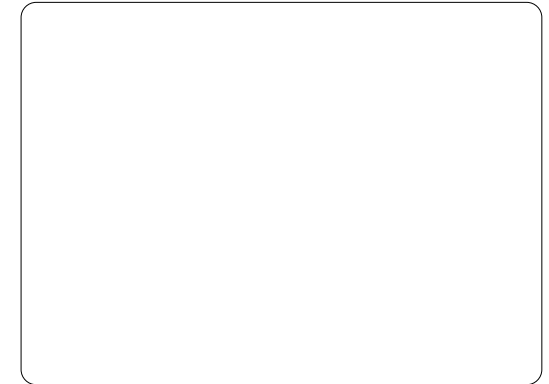

## Atop Customer Services and Supports

1. Please contact your local dealers or Atop Technical Support Center at the following numbers.  
+ 886-3-550-8137 (Atop Taiwan) / + 86-21-6495-6232 (Atop China)
2. Please report the defected problems via Atop's Web site or E-mail account  
Web Site : [www.atop.com.tw](http://www.atop.com.tw), e-mail : [service@atop.com.tw](mailto:service@atop.com.tw)  
Web Site : [www.atop.com.cn](http://www.atop.com.cn), e-mail : [service@atop.com.cn](mailto:service@atop.com.cn)

— Any changes to this material will be announced on Atop's website. —

# Mechanical Dimensions

## Front View

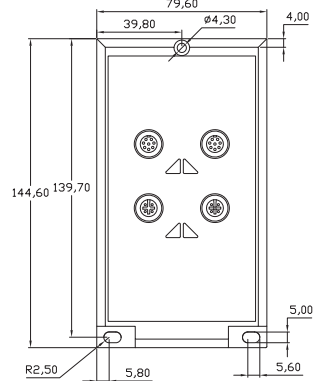

## With DIN-Rail

### Top View

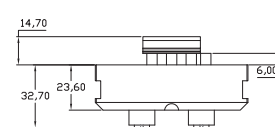

### Side View

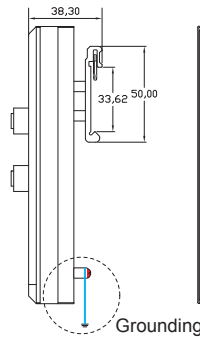

### Rear View

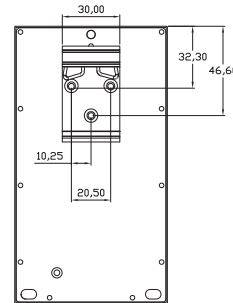

## Without DIN-Rail

### Top View

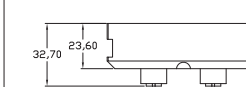

### Side View

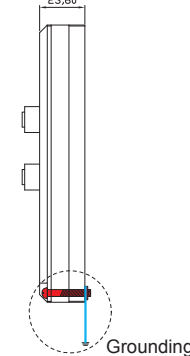

### Rear View

